



## Specialty Applications Model ST-1250 Vertical Discharge



*A sampling of the products that can be fed.*

### Overview:

This Pro Series ST-1250 is a feeder featuring a vertical discharge that dispenses product straight down at 90 degrees. It is designed to deliver inserts into open-top cartons, stand-up pouches, magazines, books, and more. Easily adjusts to accommodate various product sizes and types.

### Applications:

- Coupons
- Invoices
- Instruction Sheets
- Product Inserts
- Business Reply Cards

### Specifications

<b>Maximum Product Size:</b>	.....	8.5 W x 11 L in (215.9 x 279.4 mm)*
<b>Minimum Product Size:</b>	.....	3.75 W x 3.75 L in (95.25 x 95.25 mm)*
Optional:	.....	2 W x 2.5 L in (50.8 x 63.5 mm)*
<b>Min/Max Product Thickness:</b>	.....	.003-1.0 in (.076-25.4 mm)*
<b>Belt Speed:</b>	.....	5500 in/min (140,000 mm/min)
<b>Electrical Requirements:</b>	.....	115/230vac, 50/60Hz, 6A
<b>Weight:</b>	.....	89 lbs. (40.367kg)
<b>Warranty:</b>	.....	One-year limited

\*Contact us for product sample evaluation

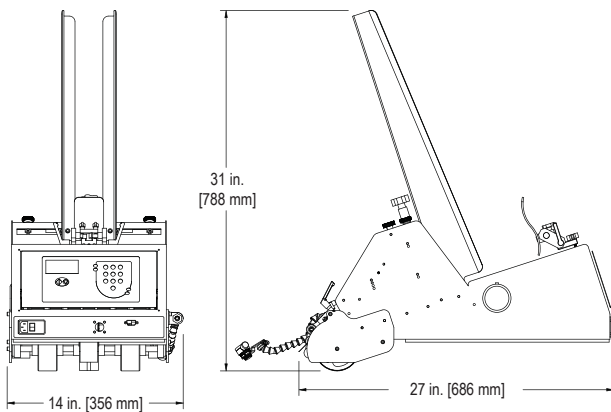

315 27th Avenue NE · Minneapolis, MN 55418 · USA  
(763) 502-0000 · www.streamfeeder.com · E-mail: sales@streamfeeder.com

# Barry-Wehmiller