

Feeder/Dispenser



We Have Your Solution.™

RELIANT SERIES Model 3700



OVERVIEW

Designed for dependable one shot and batch count feeding, the Reliant 3700 is ideal for collating and envelope inserting applications.

The Reliant 3700 is designed to be a flexible and innovative solution to even the most challenging applications. A wide array of easily configured features enable the Reliant 3700 to be adapted for optimal performance based on specific application requirements.

Experience versatile feeding performance to reliably separate, singulate, and deliver a wide range of product types and sizes.

TECHNICAL DATA

Maximum Product Size: 11.75 W x 14 L in (298.5 x 355.6 mm)
Minimum Product Size: 3.75 W x 3.75 L in (95.3 x 95.3 mm)
Optional: 2 W x 2.5 L in (50.8 x 63.5 mm)
Min/Max Product Thickness:003-1.0 in (.076-25.4 mm)
Speed: 5700 in/min (144,780 mm/min)
Batch Size: 1 to 99 pieces
Electrical Requirements: 115/230vac, 50/60Hz, 3A
Weight: 75 lbs. (34kg)
Warranty: One-year limited

APPLICATIONS

- Simple collator systems
- Wrapper infeed conveyors
- Stand-alone applications
- Feeding inserter gripper jaw or open track station

FEATURES

- Ideal for use with infeed conveyors and "jumbo" format Bell+Howell, Mailcrafters, and similar style gripper arm inserters
- Durable steel construction/powder coat paint
- Quality precision parts
- Perfect for collating applications
- Tool-free adjustments for fast setups and changeovers

DIMENSIONS

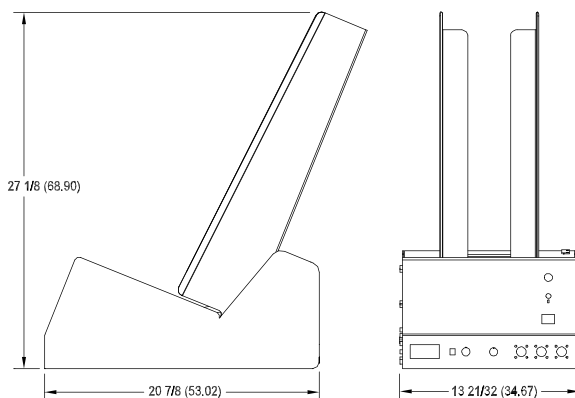

Thiele
Technologies

103 Osborne Road · Minneapolis, MN 55432-3131 · USA

t 763.502.0000 · f 763.502.0100 · www.streamfeeder.com · E-mail: sales@streamfeeder.com