

Feeder/Dispenser



We Have Your Solution.™

RELIANT SERIES Model 1500



OVERVIEW

The compact Reliant 1500 combines flexible performance with superior feeding to precisely separate, singulate, and present many types and sizes of product to your inserter's gripper jaw. Job setups and changeovers are easily and quickly accomplished. A large capacity hopper is conveniently loaded from the front or back. The brushless and clutch-free motor provides dependable feeding performance.

APPLICATIONS

- 6 x 9 gripper arm envelope inserters
- Phillisburg, Inserco, EMC, AMOS, Kern, and similar type inserters
- Z-fold sheets, slick stock, payment booklets, and other products that are typically fed with difficulty on an inserter

TECHNICAL DATA

Maximum Product Size:	9.25 W x 6 L in (235 x 152 mm)
	Contact us for longer insert length
Minimum Product Size:	2.125 W x 2.25 L in (54 x 57 mm)
Min/Max Product Thickness:	.003-.25 in (.076-6.35 mm)
Belt Speed:	1000 ipm (25,400 mppm)
Electrical Requirements:	115/230vac, 1A
Weight:	23 lbs. (10.43kg)
Warranty:	Two-year limited

FEATURES

- Reliable product separation
- Tool-less adjustments for easy setups and changeovers
- Compact 10 inch width allows side-by-side mounting
- Sealed precision bearings never require lubrication
- Handles most insert types, sizes, and thicknesses
- Easy to learn and operate

DIMENSIONS

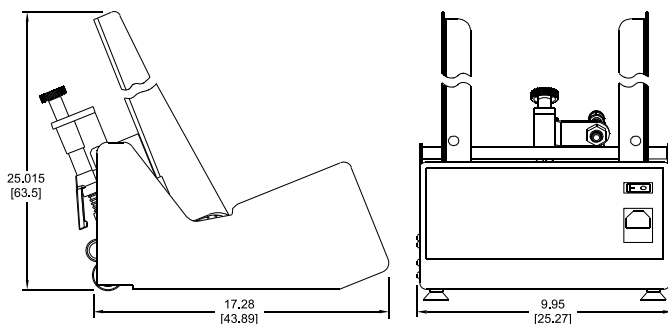

Thiele
Technologies

103 Osborne Road · Minneapolis, MN 55432-3131 · USA

t 763.502.0000 · f 763.502.0100 · www.streamfeeder.com · E-mail: sales@streamfeeder.com